

| MARCA | REFERENCIA | DENOMINACIÓN | UNIDADES |
|-------|-----------------------------|-------------------|----------|
| | ESTRUCTURA MODULARES | | |
| 1 | 04-09-00-20-00 | TORRE 600 | 2 |
| 2 | 04-09-00-32-00 | RAMPA RECTA | 2 |
| 3 | 04-09-00-10-00 | PASARELA CORTA | 1 |
| 4 | 04-09-00-27-00 | TEJADO CASTILLO 1 | 2 |
| 5 | 04-09-00-00-PL1-5 | PANEL 1-5 | 2 |
| 6 | 04-09-00-30-00 | TOGOBAN600 | 2 |

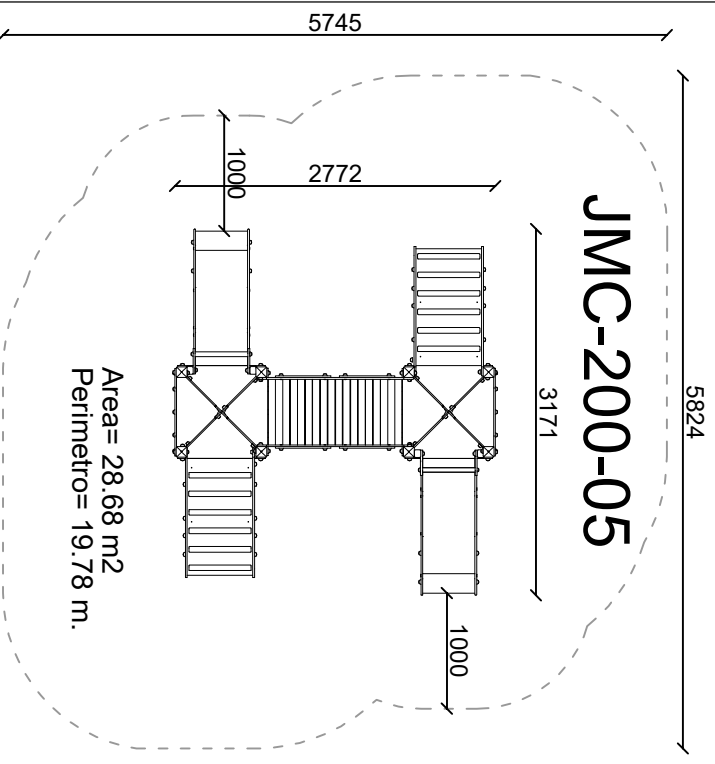

Area= 28,68 m²
Perimetro= 19,78 m.

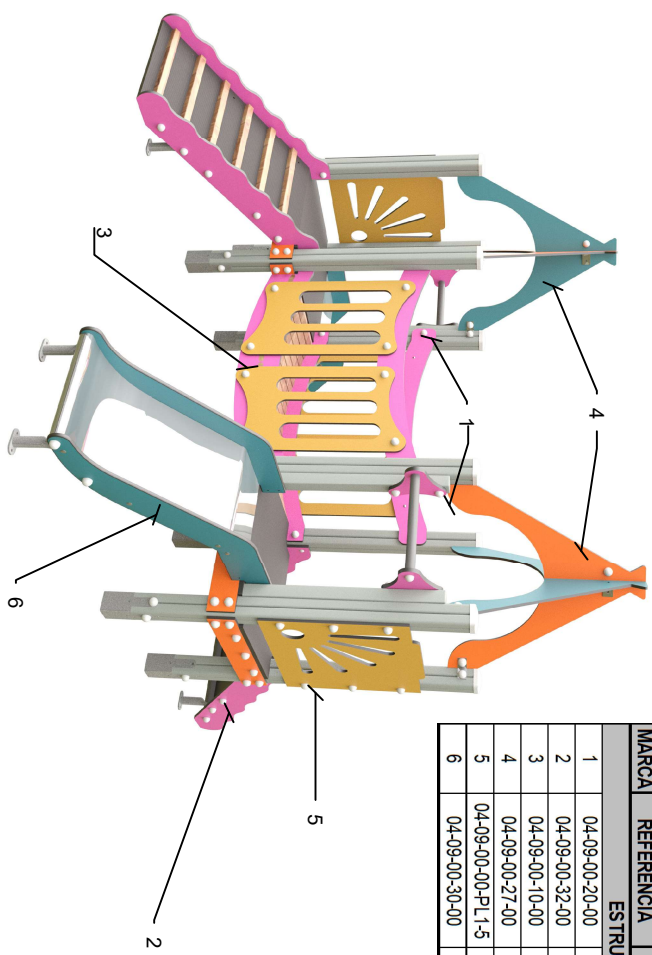

| | | | | |
|--|--|----------------|---|------------|
| FECHA: Octubre 2008 | JMC-200-05 | JMC-200-05 |  | |
| 04/02/2014 | Temática neutra Modelo 5 Hasta 6 años | 04-09-05-00-00 | | |
| VISTA GENERAL CON COTAS EN MILIMETROS | | | | |
| Plano propiedad de Arcourban S.L., protegido por ley 3/91 sobre competencia desleal. La empresa receptora se compromete a un tratamiento confidencial de la información emitida en este plano. | | | | |
| ESCALA | 1 ^a | 17/01/2014 | 2 ^a | 13/05/2019 |
| | 3 ^a | 10/10/2025 | 4 ^a | |